

Journée technique du Pôle Eclairage du Cerema :
Lumière sur l'éclairage urbain de demain



**EVALUATION DES PERFORMANCES
DE L'ÉCLAIRAGE**

Vincent Boucher
Cerema Angers

Eclairage urbain - routier



- 1^{er} acteur : Luminaires
- 2nd acteur : Chaussée (propriétés optiques)
- 3rd acteur : Yeux du conducteur

Eclairage

— 1^{er} acteur : luminaire

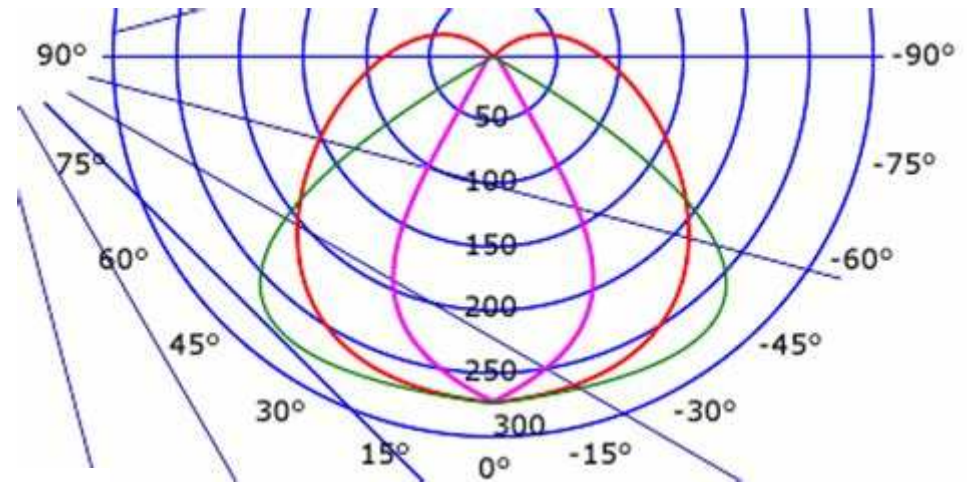
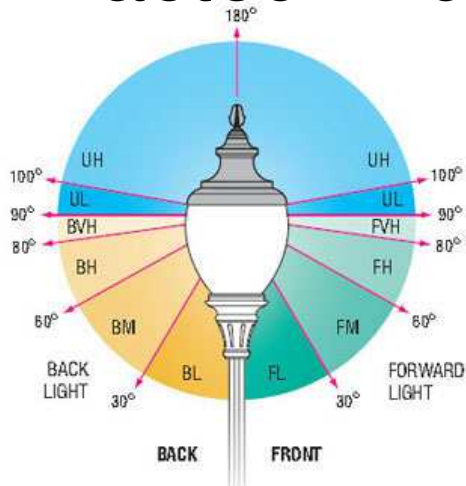

Spotlight



Narrow Beam Angle

DownLight



Wide Beam Angle



Eclairage - Mesures

— 1^{er} acteur : luminaire

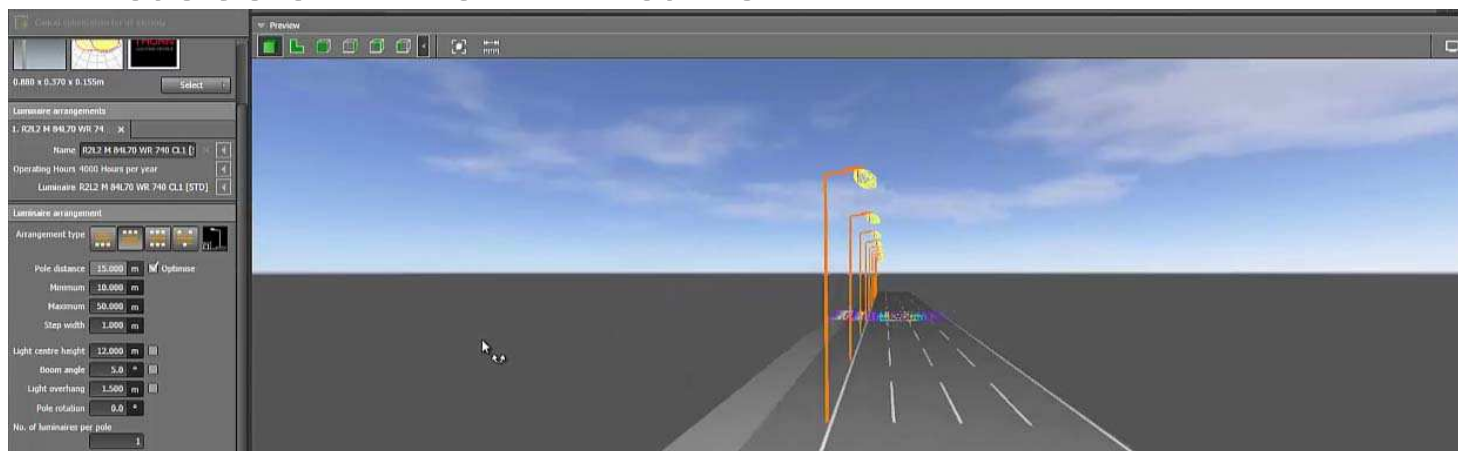

Eclairage - Mesures

— 1^{er} acteur : luminaire

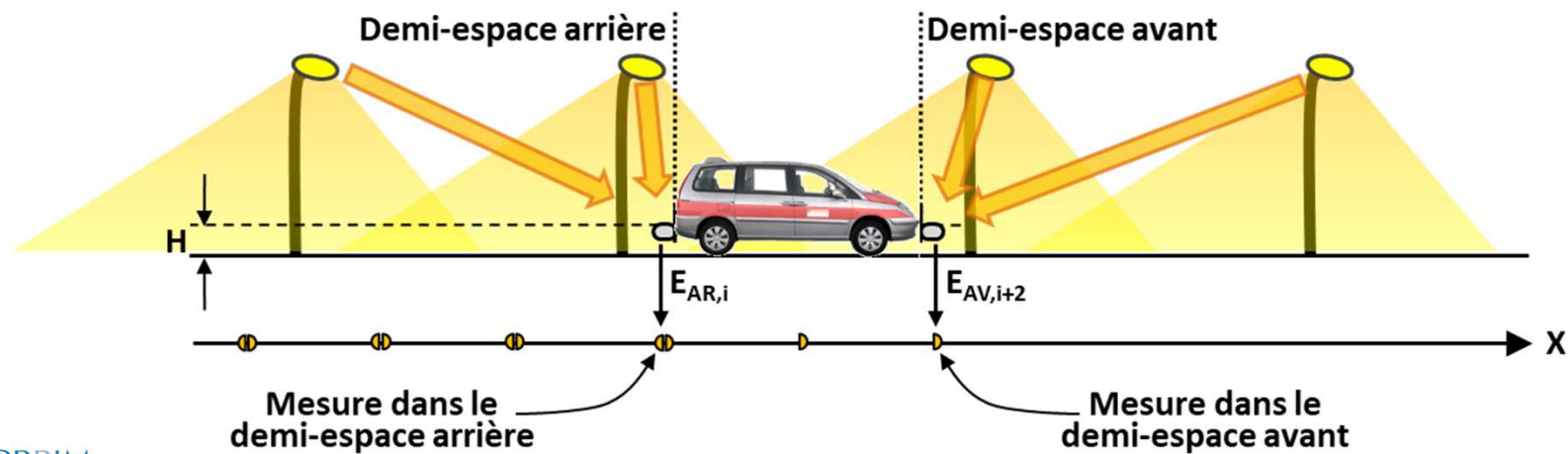

Eclairage - Mesures

— 1^{er} acteur : luminaire

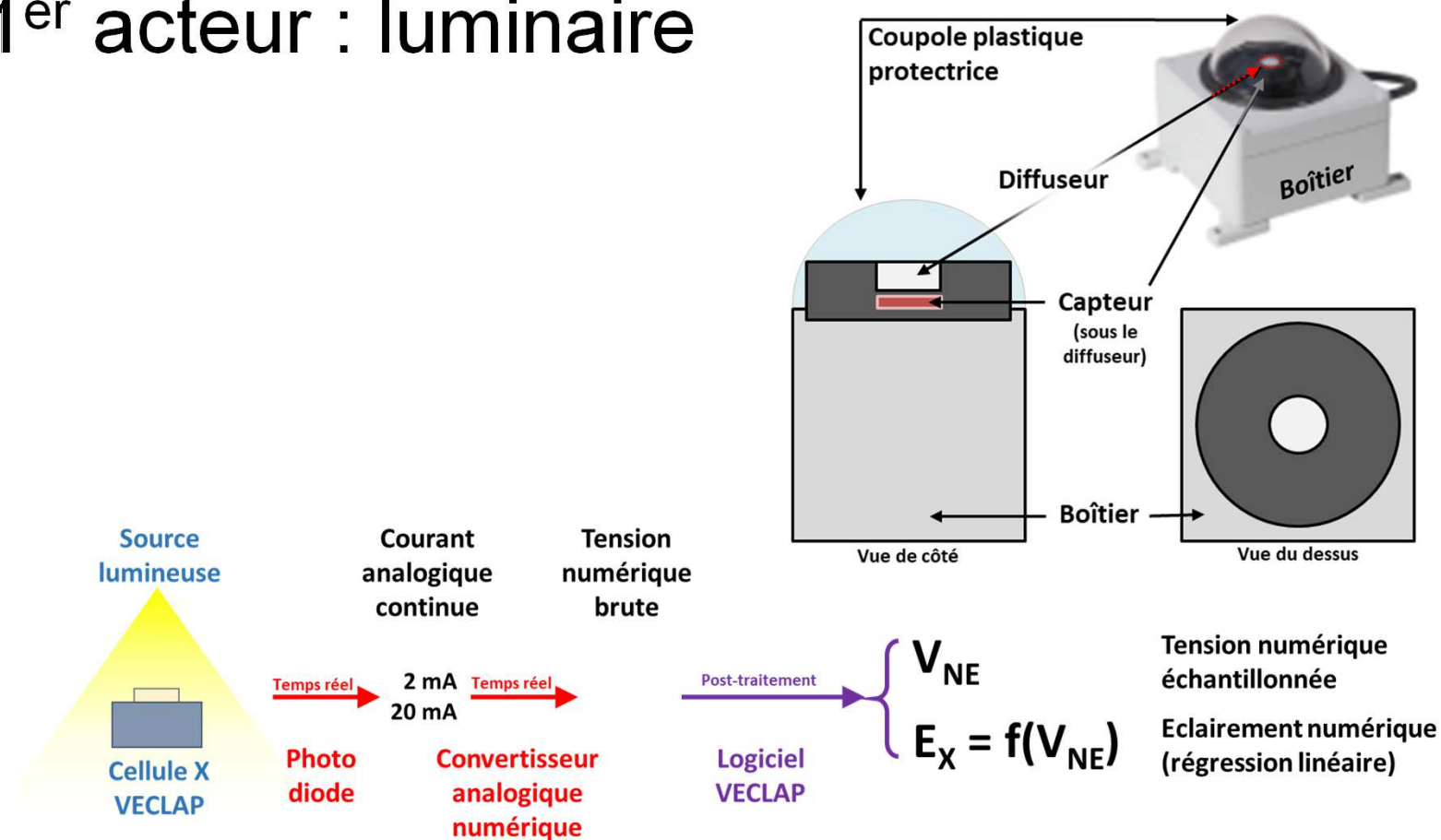

Eclairage - Mesures

— 1^{er} acteur : luminaire



Mesures d'éclairage en continu

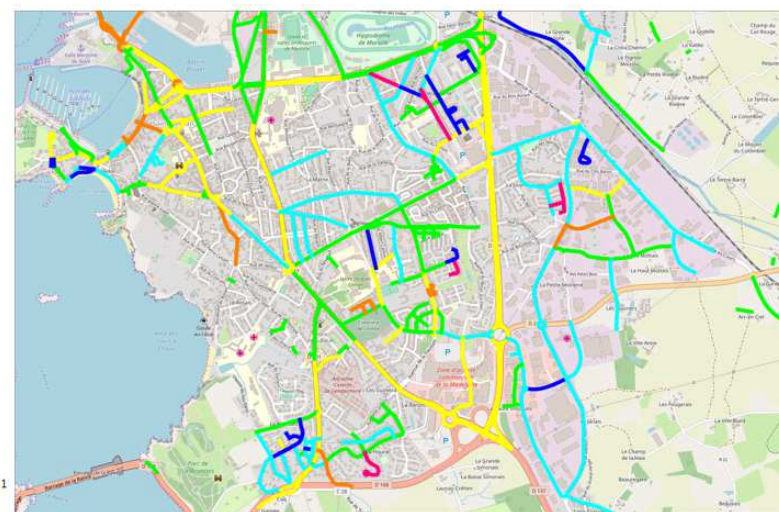

Restitution par rue

Eclairage

— 2nd acteur : Propriétés de la chaussée

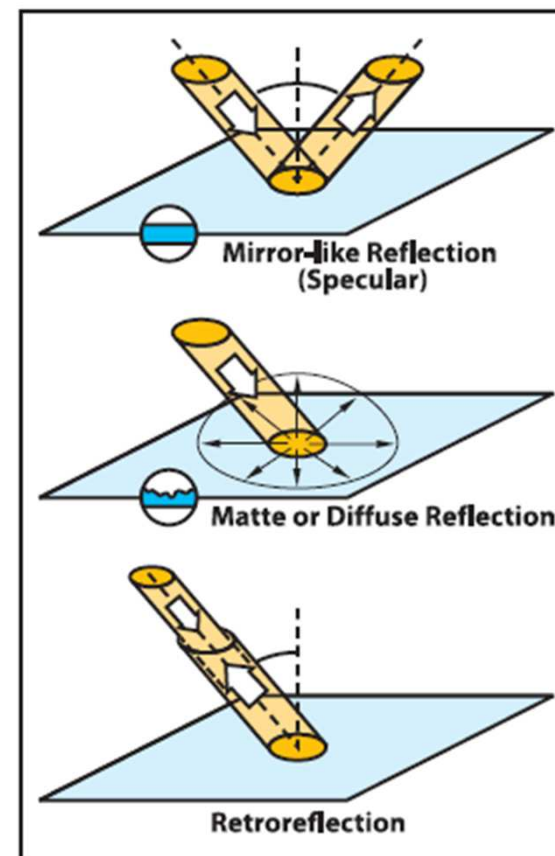
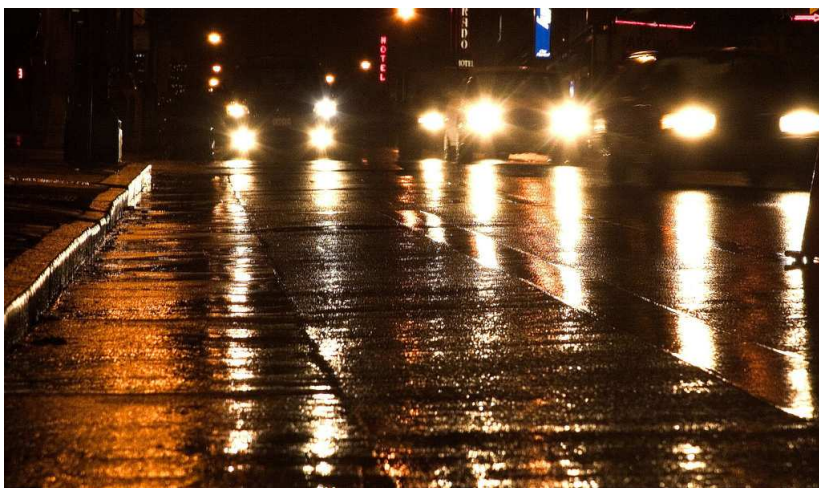

Eclairage - Mesures

— 2nd acteur : Propriétés de la chaussée

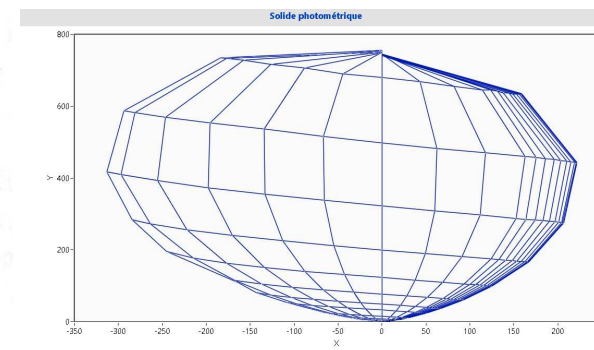
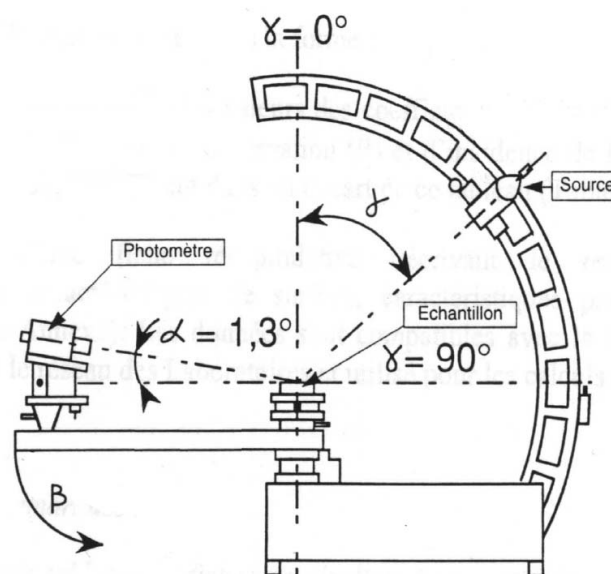

Eclairage - Mesures

— 2nd acteur : Propriétés de la chaussée

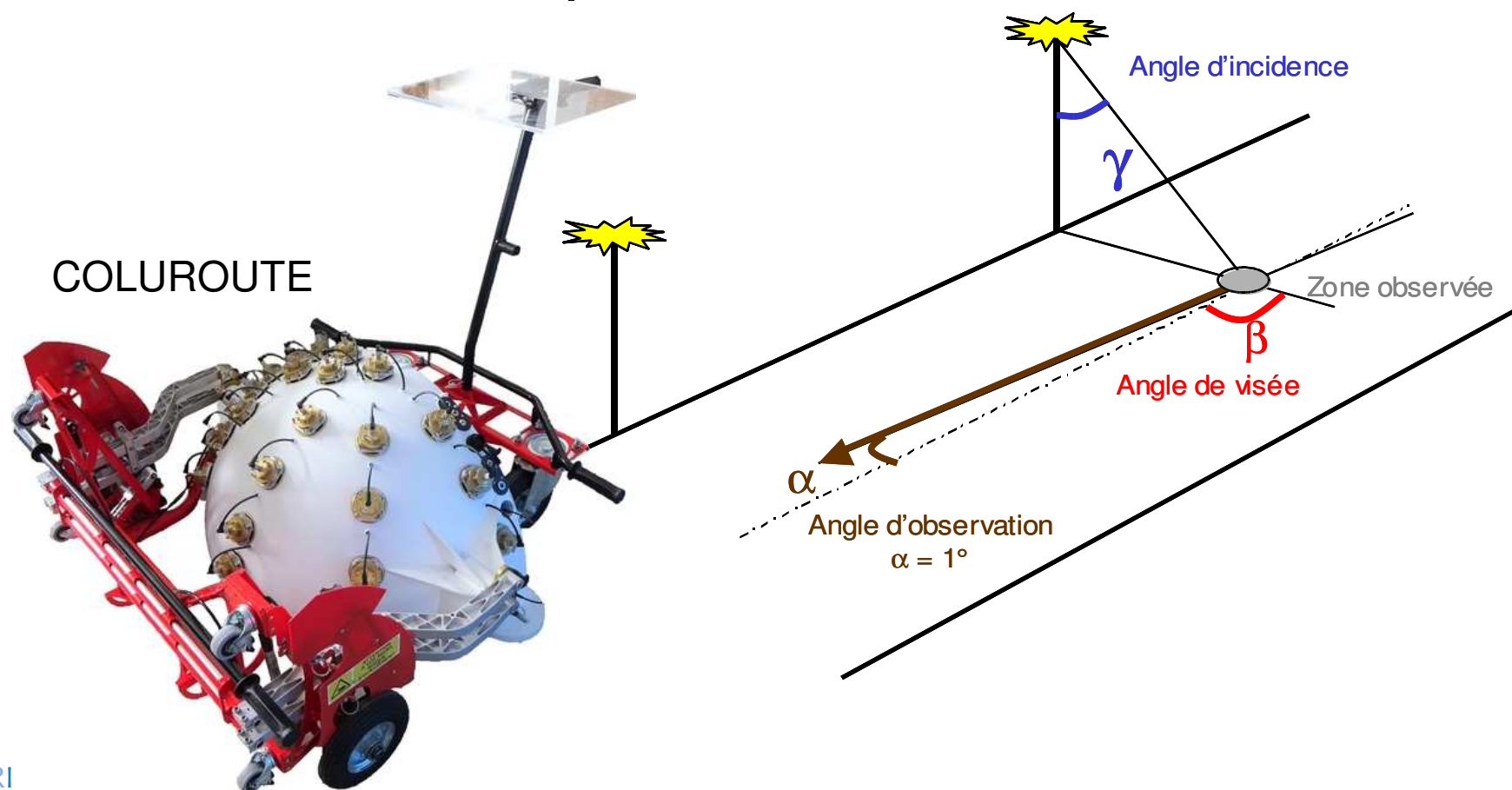

Eclairage - Mesures

— 2nd acteur : Propriétés de la chaussée

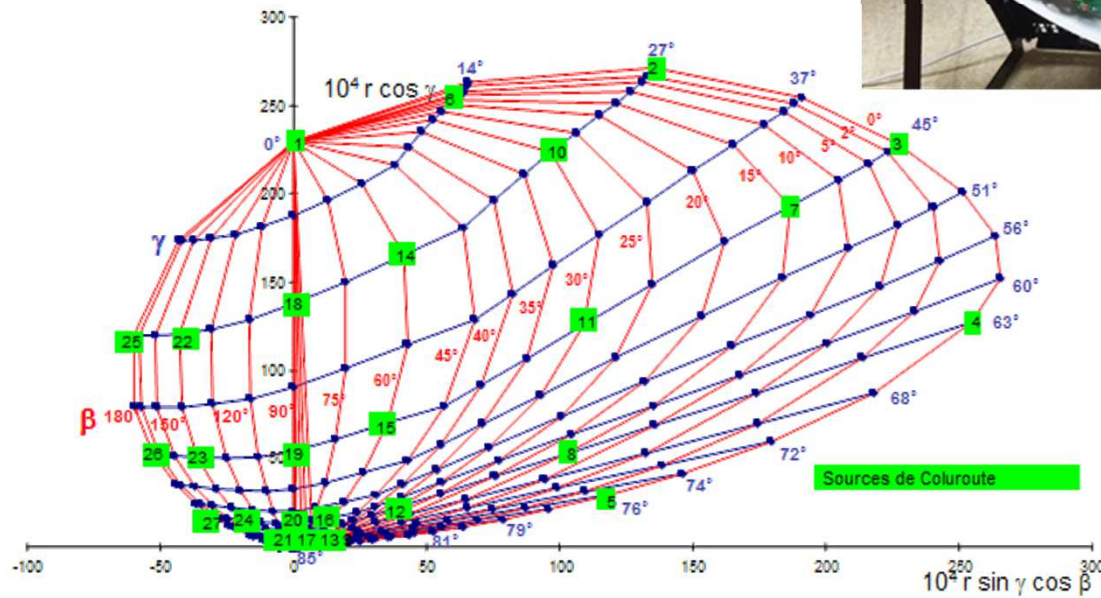
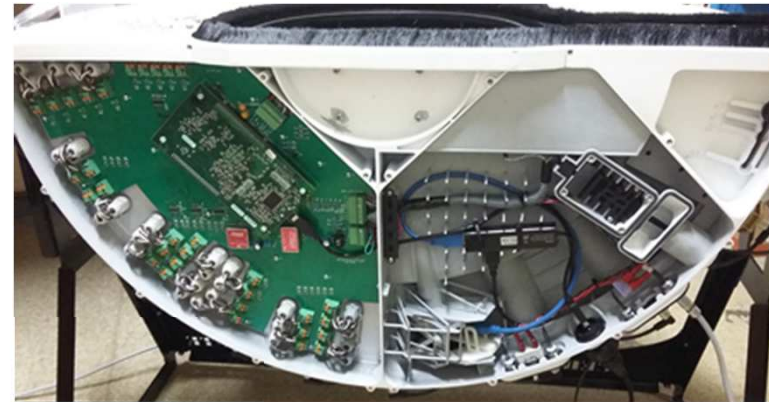

Eclairage

— 3^{ème} acteur : Les yeux du conducteur

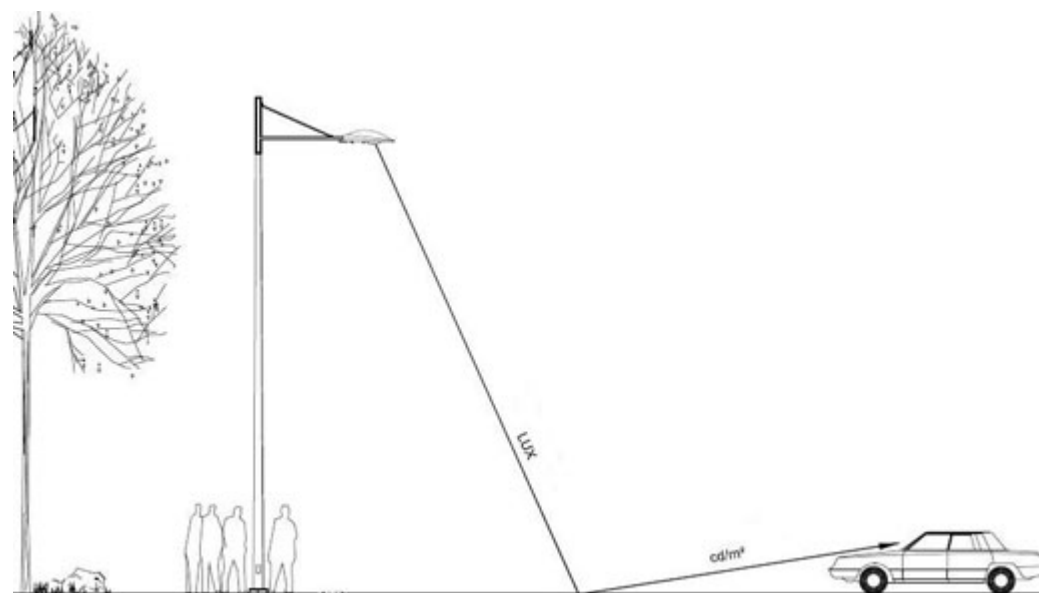

Eclairage - Mesures

— 3^{ème} acteur : Les yeux du conducteur

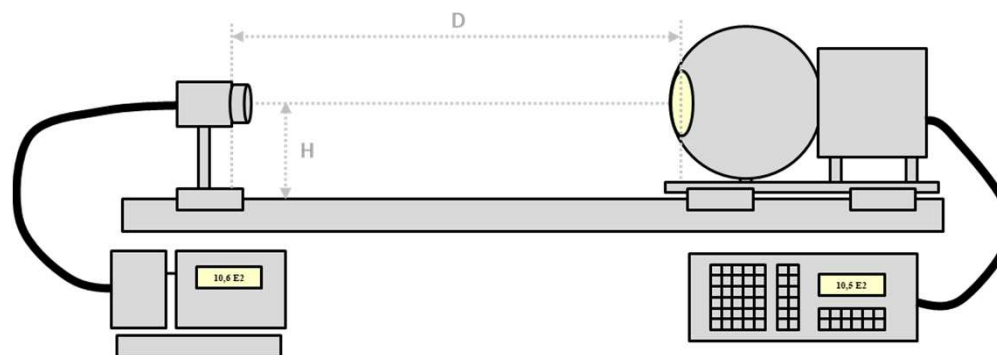

Eclairage - Mesures

— Mesurer la Luminance

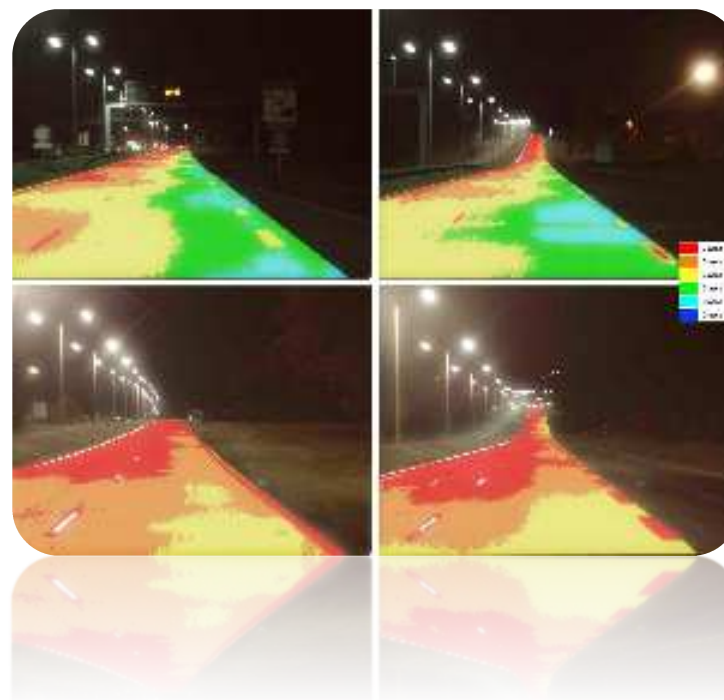

Eclairage - Mesures

— Mesurer la Luminance

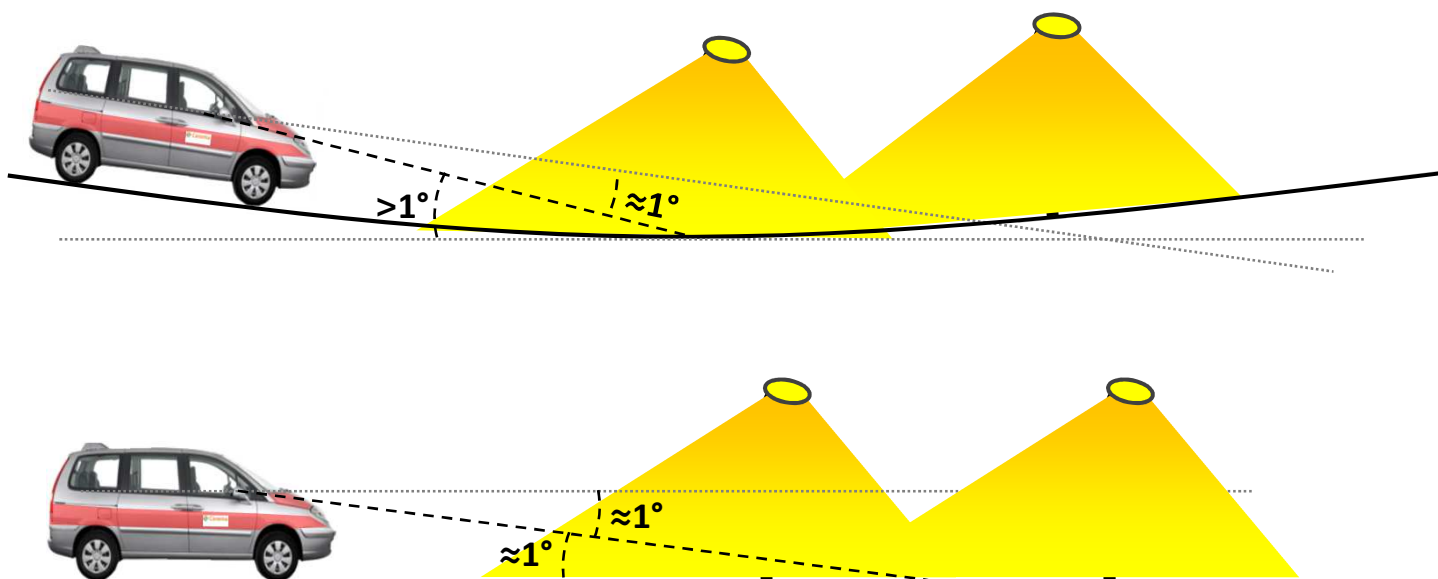

Eclairage - Mesures

— Mesurer la Luminance

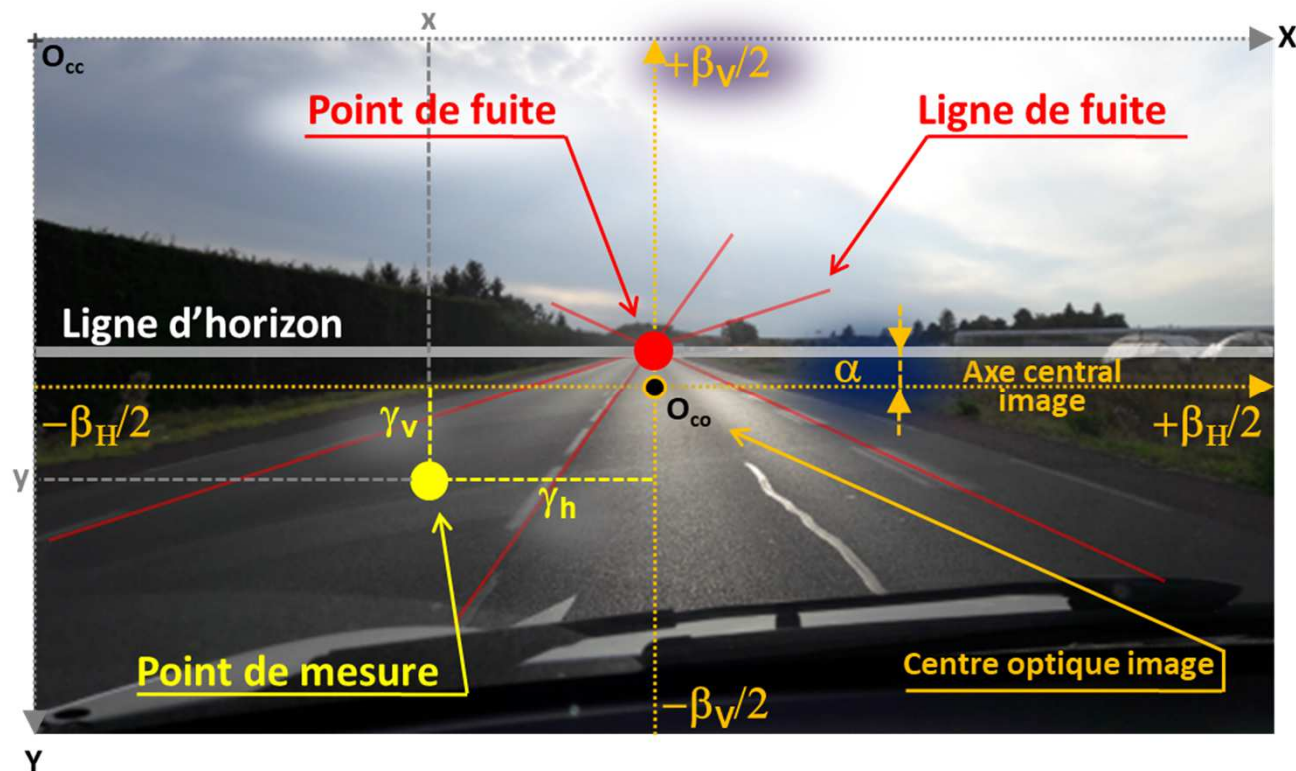

Eclairage - Mesures

— Images en Luminance

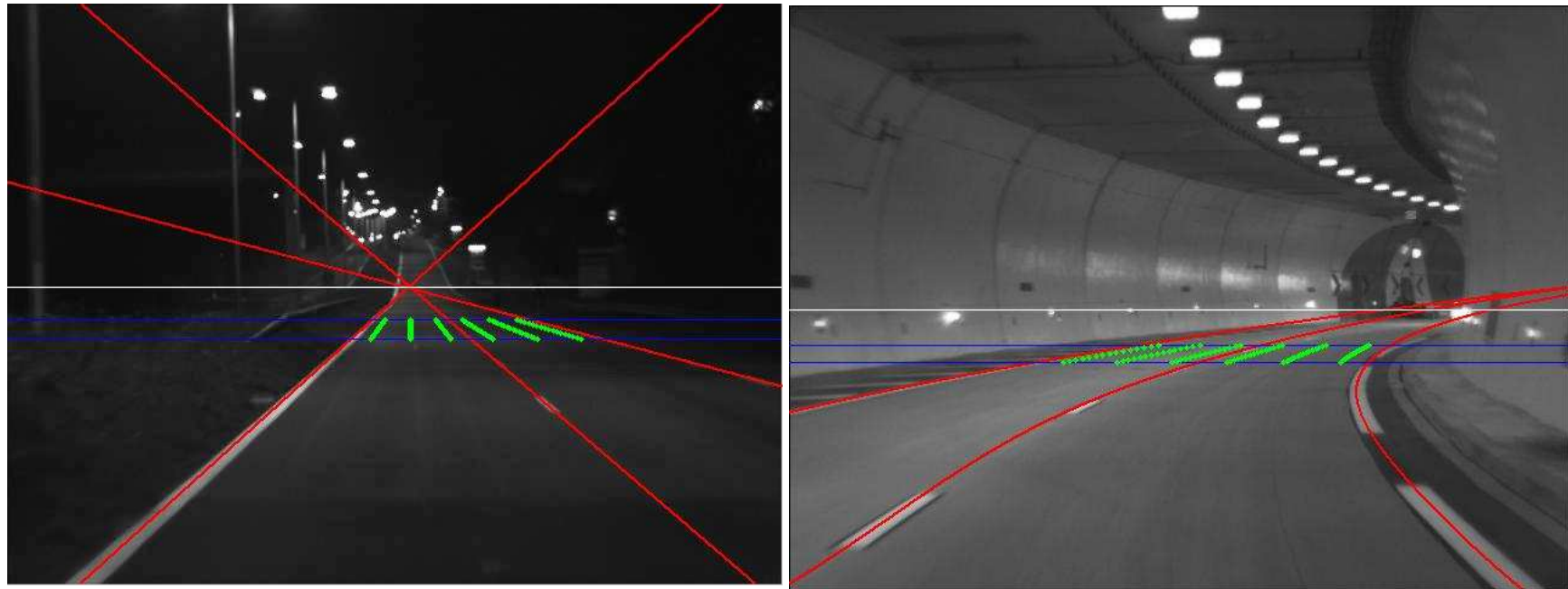

Eclairage - Mesures

— résultats

Renfort entrée de tunnel

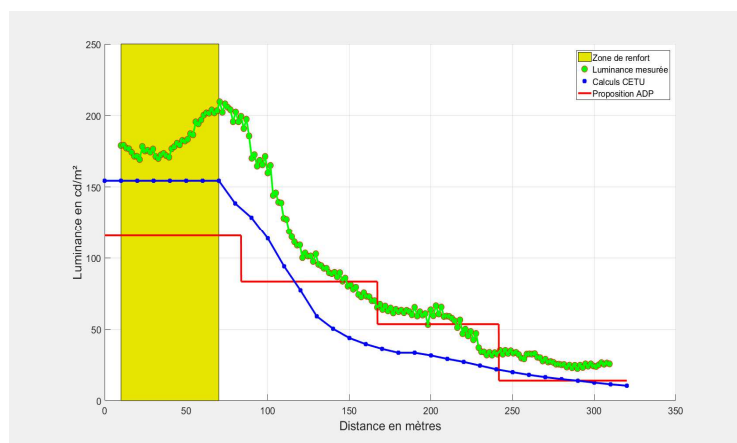

Luminance sur une voie

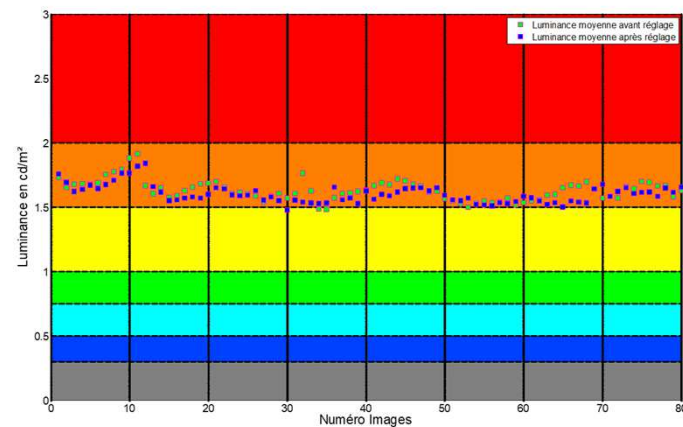

Uniformité sur une voie

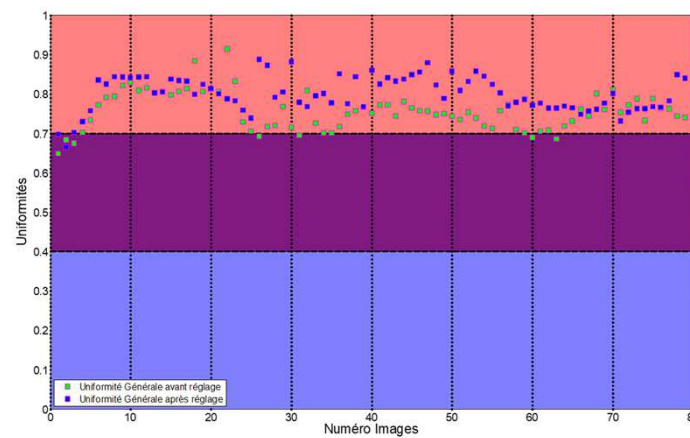

Zoom sur une étude pilote pour de la modulation d'éclairage



Schéma Directeur d'Eclairage



Direction territoriale Méditerranée

Schéma directeur d'éclairage
de la ville de Saint Malo

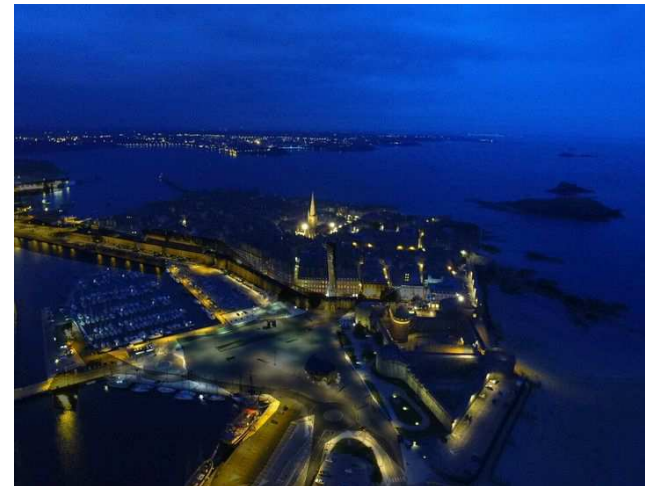
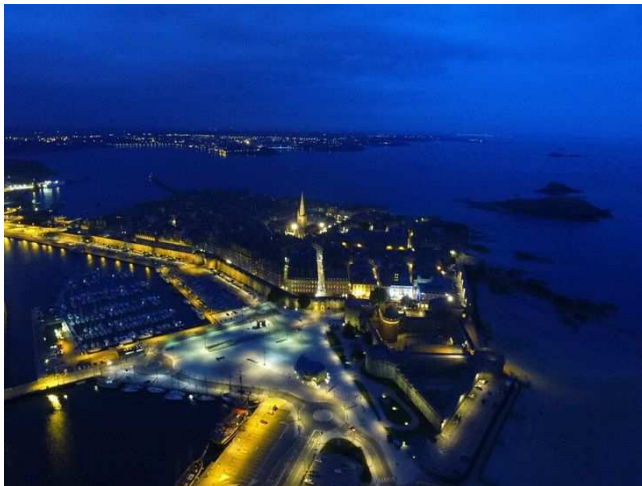

— Connaître son patrimoine d'éclairage :

- 10617 points lumineux
- 1274 armoires
- *Recensement des dispositifs de modulation*

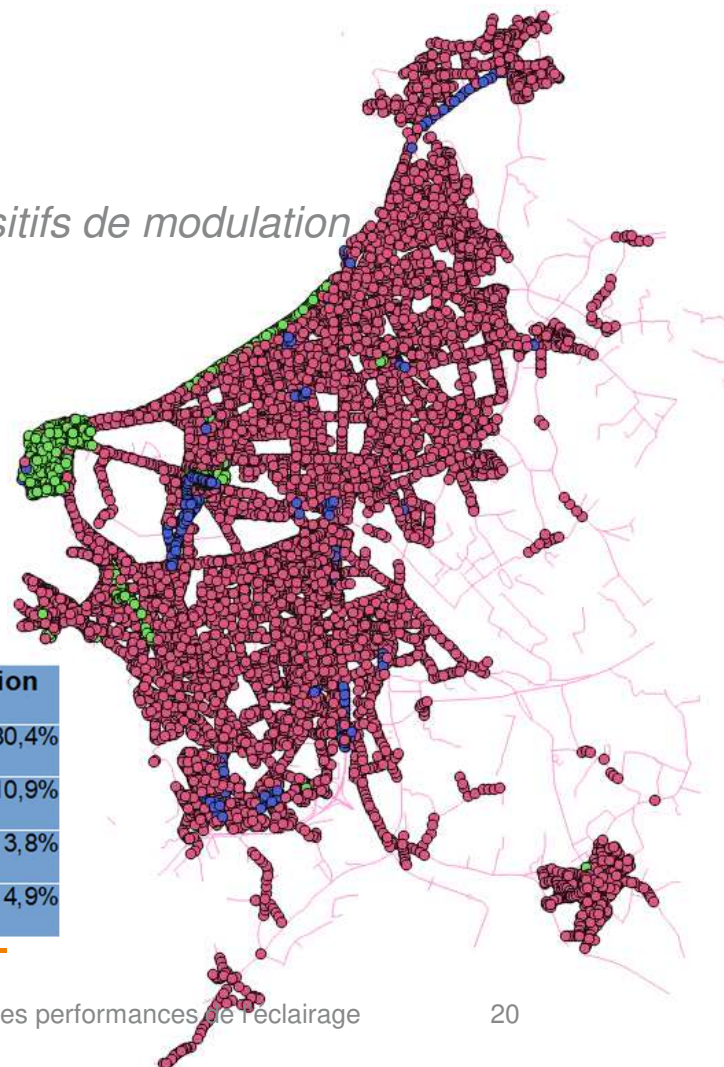

Type de source	Nombre	Proportion
SHP	8540	80,4%
Iodure Metallique	1153	10,9%
LED	401	3,8%
Autres	523	4,9%



Schéma Directeur d'Eclairage

— Phase initiale : Classification des voies selon la norme EN 13201

Classe 1 = 22 lux

Boulevard important
Ambiance lumineuse forte

Classe 2 = 17 lux

Boulevard important
Ambiance lumineuse normale



Schéma Directeur d'Eclairage

— Phase initiale : Classification

Classe 3 = 18 lux

Boulevard secondaire
Ambiance lumineuse forte

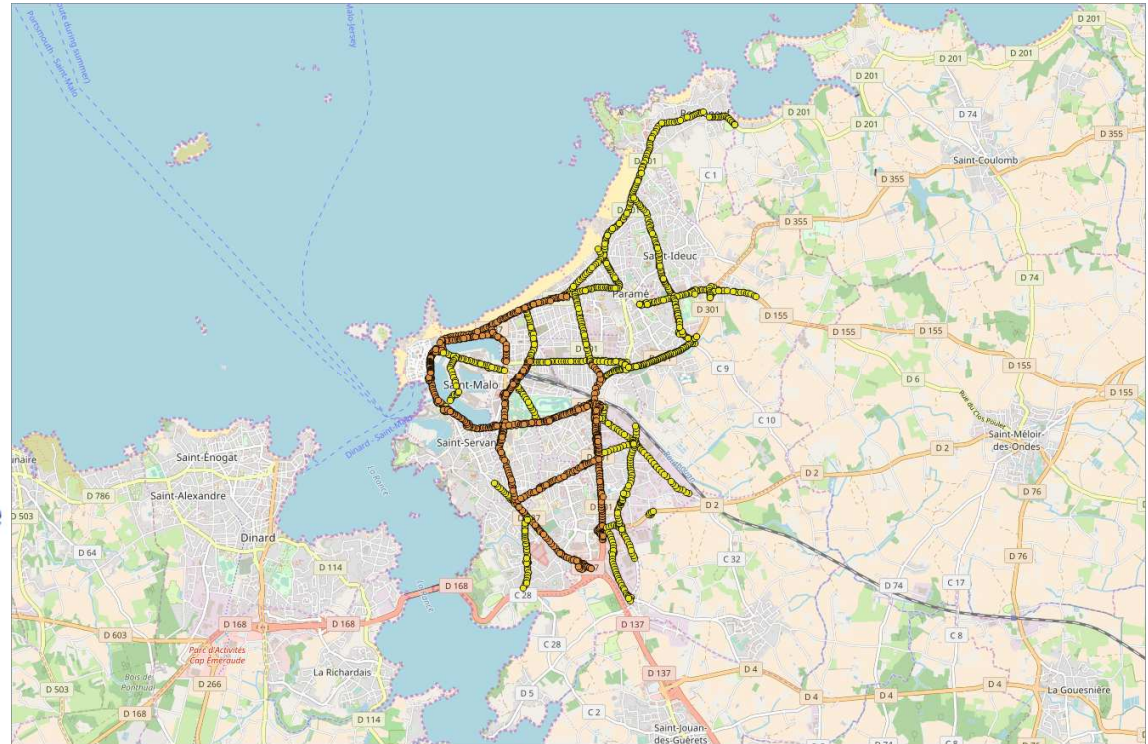
Classe 4 = 14 lux

Boulevard secondaire
Ambiance lumineuse normale



Schéma Directeur d'Eclairage

— Phase initiale : Classification

Classe 6 = 8 lux
Lotissement

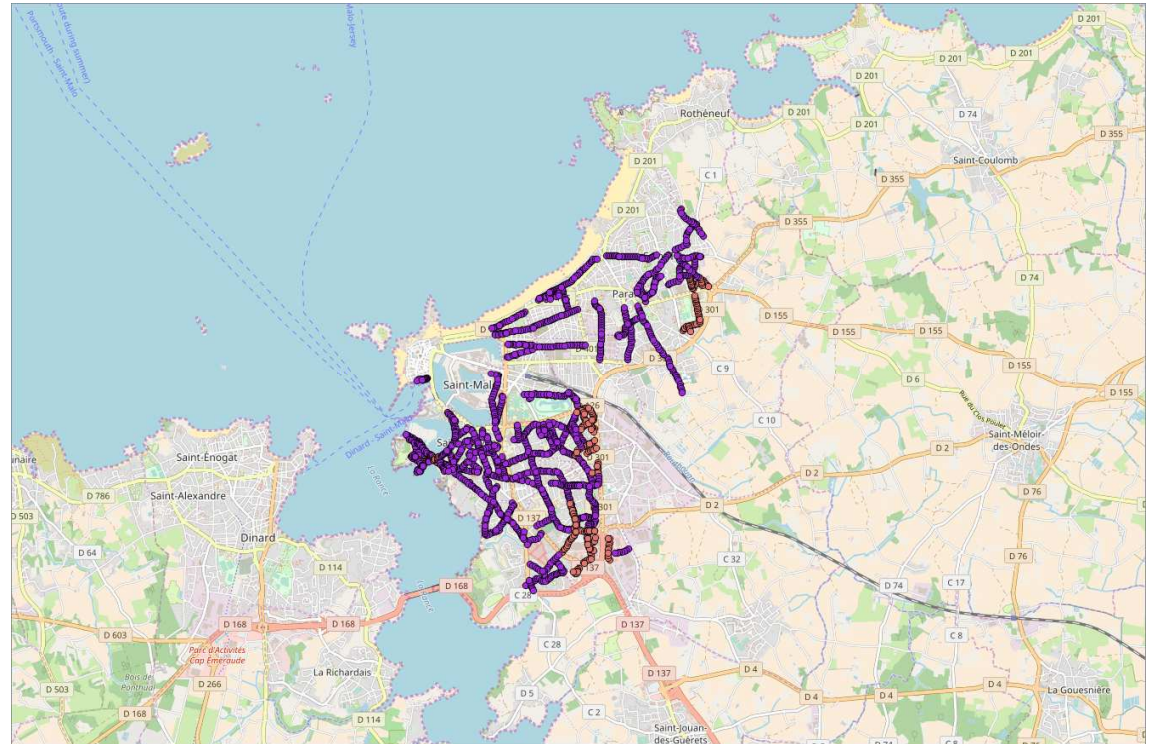

Schéma Directeur d'Eclairage

— Phase initiale : Classification

Classe 9 = 15 lux

Voies commerciales / Intra
Ambiance lumineuse forte

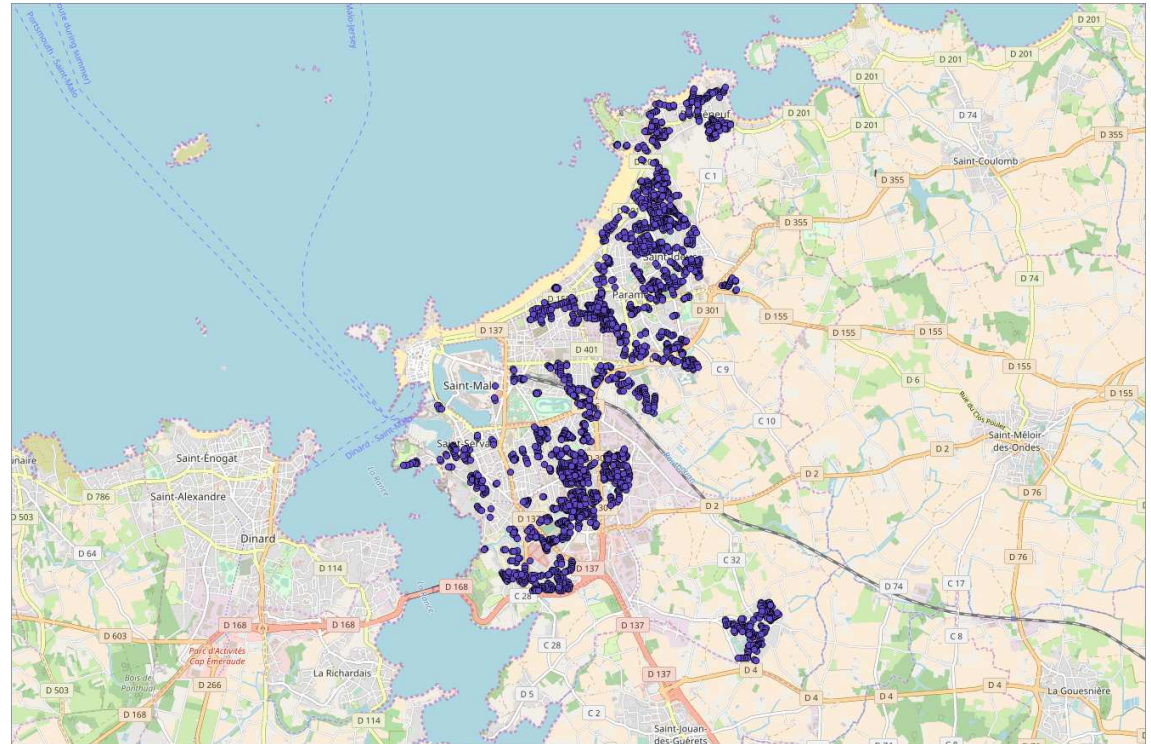
Classe 10 = 11 lux

Voies commerciales / Intra
Ambiance lumineuse normale



Schéma Directeur d'Eclairage

— Phase initiale : Classification

Classe 11 = 7 lux
Digues / piétons

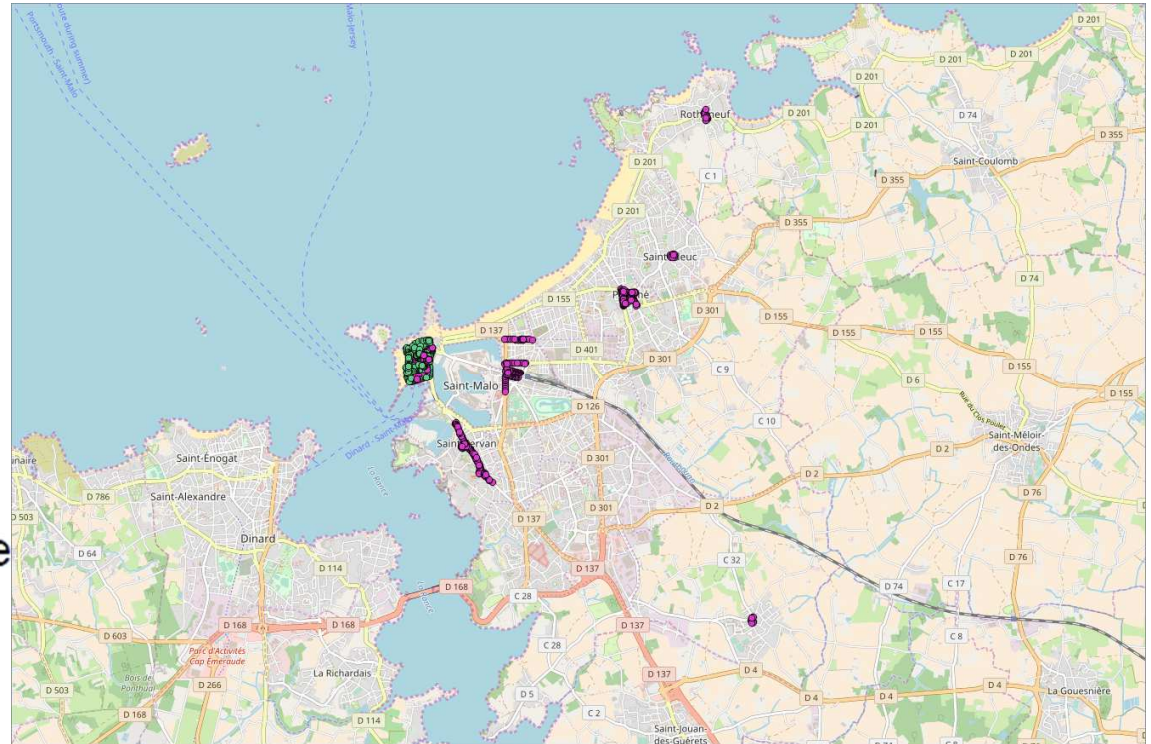
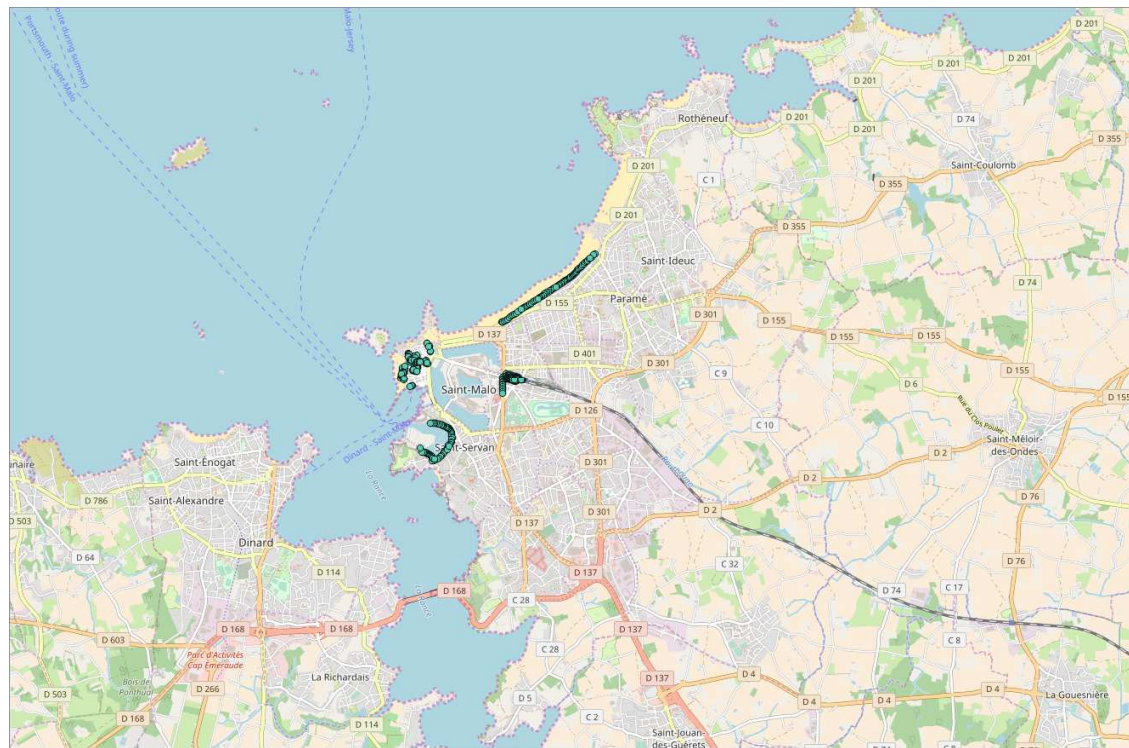

Mesures d'éclairage

— Diagnostic photométrique en éclairage



Mesures VECLAP sur Saint-Malo

89 kilomètres de linéaire mesuré

280 000 points de mesure exploités

- C0 > 50
- C1 > 30
- C2 > 20
- C3 > 15
- C4 > 10
- C5 > 7.5
- Peu lumineux > 1
- HS < 1

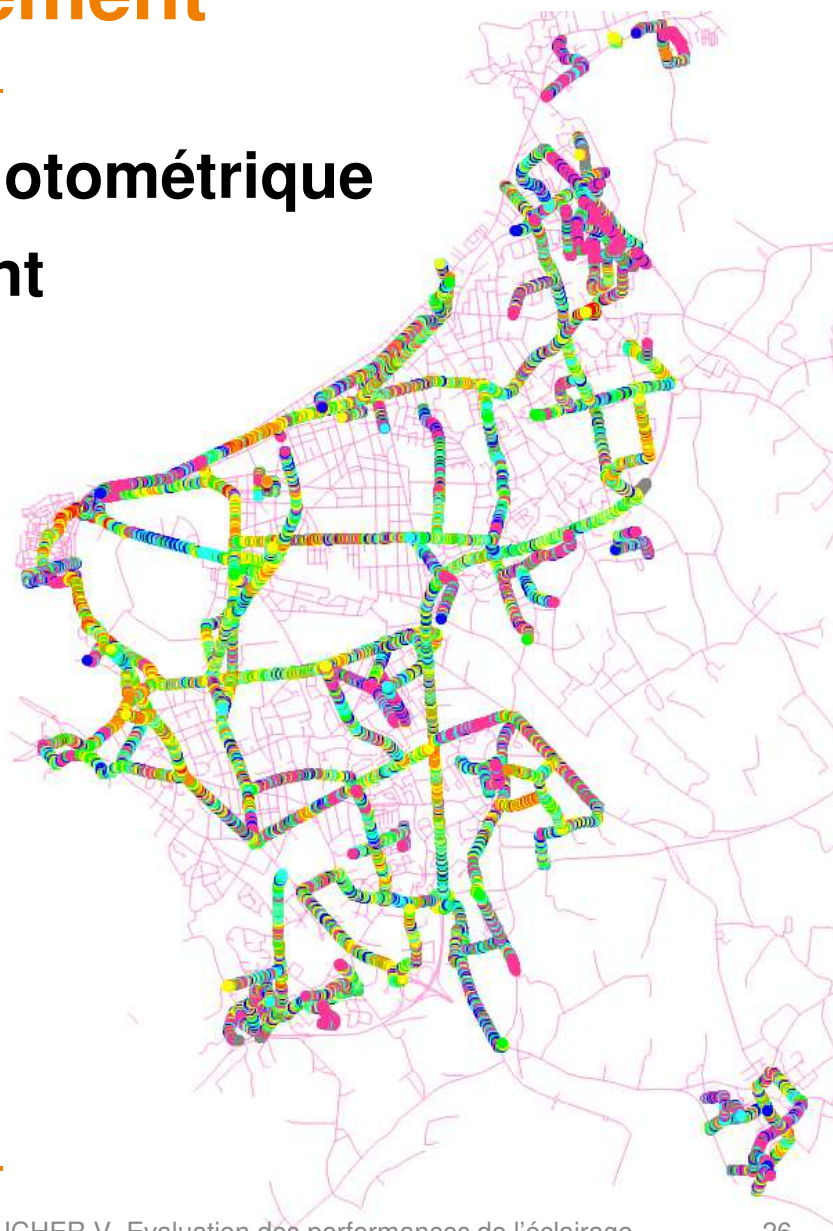

Analyse macro des mesures

— Comparer objectifs et diagnostic

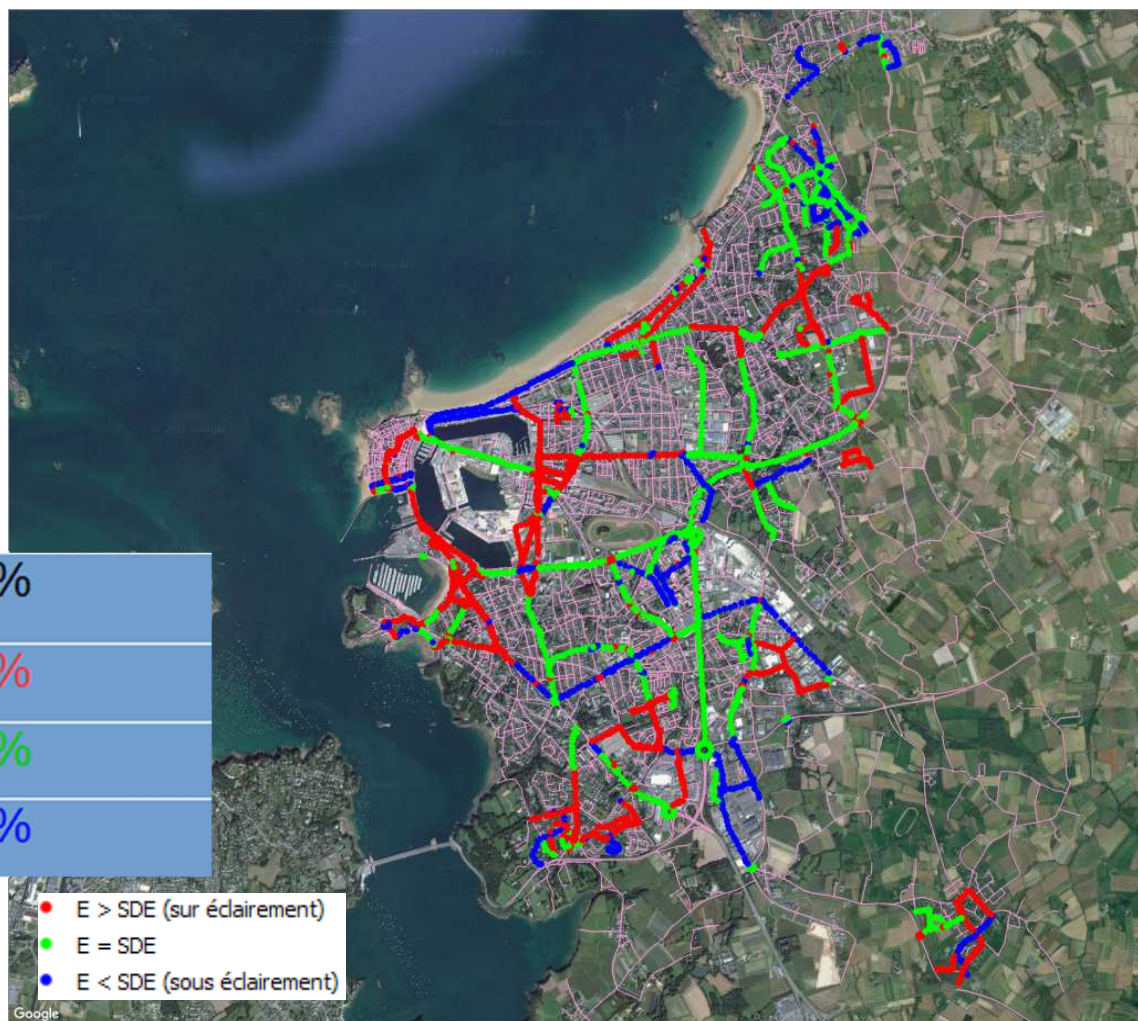

Taux de caractérisation	31 %
Taux de sur éclairage	41 %
Taux de juste éclairage	38 %
Taux de sous éclairage	21 %



MERCI DE VOTRE ATTENTION

Vincent Boucher

vincent.boucher@cerema.fr



Journée technique du Pôle Eclairage du Cerema :
Lumière sur l'éclairage urbain de demain

